

| | | |
|-----|-------------|------|
| ECN | DESCRIPTION | DATE |
|-----|-------------|------|

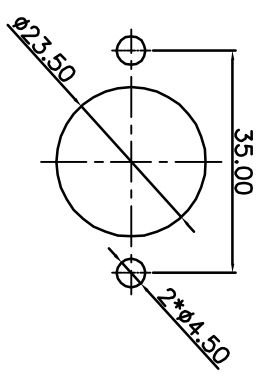

Panel Cut-Out

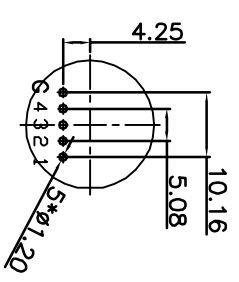

PCB Layout

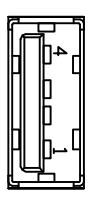

Pin Assignments
Front View 前视图

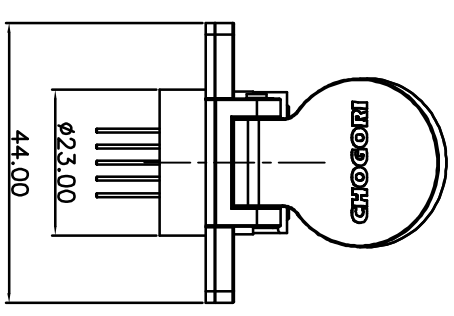
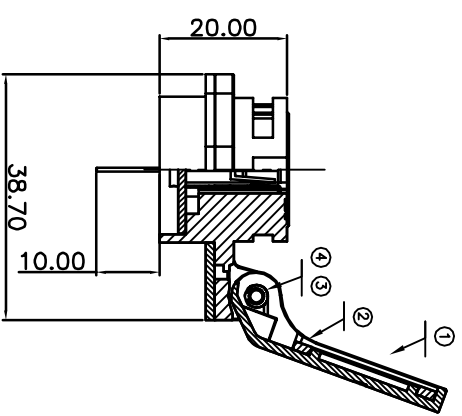
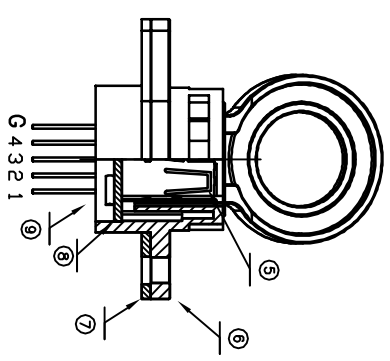
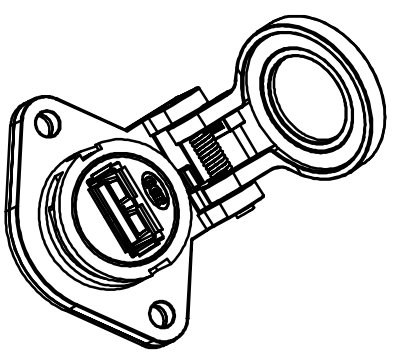

NOTE:
1、① Important Dimension.
(② 为重点控制尺寸)

| NO | NAME | COLOR | SPECIFICATION | QTY | NOTE |
|----|----------------|-------|-------------------|-----|------|
| 9 | Terminal Block | Black | Nylon+GF | 1 | |
| 8 | PCB | Green | FR-4;UL 94 V-0 | 1 | |
| 7 | Gasket | Black | Silicon Gel | | |
| 6 | Connector | Black | Nylon+GF | 1 | |
| 5 | Connector | | USB-A Female Type | | |
| 4 | Axle | White | Stainless Steel | 1 | |
| 3 | Spring | White | SUS 304 | 1 | |
| 2 | Gasket | Black | Silicon Gel | 1 | |
| 1 | Cap | Black | Nylon+GF | 10 | |

名称 NAME

USB A Type Female Conn.
PCB Lock Panel (Rhombus)

材料 MATERIAL

未注公差 TOLERANCE UNLESS OTHERWISE SPECIFIED:
线性尺寸 LINEAR DIMENSION:
X ±0.30 角度 ANGULAR:
.X ±0.20 ±2°
.XX ±0.10 ±1°
.XXX ±0.05 ±0.5°

| | |
|--------------------------|-----------|
| 表面粗糙度 SURFACES ROUGHNESS | 处理 FINISH |
| 设计 DRAWN | Key.G |
| 校对 CHECKED | |
| 标准化 STANDARDIZE | |
| 批准 APPROVAL | |
| 客户 CUSTOMER | |

| | |
|------------------------------|-------------|
| 型号 TYPE | 34000000-05 |
| 代号 PART NO. | |
| 第一角投影 FIRST ANGLE PROJECTION | |
| 阶段标识 STAGE | |
| 质量单位 MASS UNIT | mm |
| 比例 SCALE | |

共 页 第 页 SHEET OF 第 版 REVISION
CHOGONI 深圳乔合里科技有限公司
Shenzhen Chogoni Technology Co.,Ltd