



- 50 mm ball
- waterproof scroll wheel
- IP68 sealing

IEC60945 MARINE IP68 TRACKBALL WITH SCROLL WHEEL

The LTSX50 "Scroll&Roll" trackball is the worlds' first waterproof trackball with integrated IP68 scroll wheel. Easy scrolling & rolling throughout your applications, even in the harshest of environments. It's equipped with a waterproof large 50 mm laser trackball. A removable top ring facilitates the cleaning of ball and ball compartment for use in even the most dusty environments. The use of stainless steel for the various parts ensures the best resistance in salty or greasy environments. Due to its outstanding sealing, its professional style and its industrial robustness, these trackball units are the best suited pointing device for all harsh or hostile environments, indoor and outdoor.

These panel mount types are available with panel mount studs or with holes (for countersunk M4 screw). Furtheron you can choose for a blank or matt blackened carrier plate. A silicone sponge gasket is included with the module to ensure adequate sealing into the customers' panel or console and a cover plate on the rear side protects the components. This series is directly plug compatible to PS/2 or USB ports and offers very straight forward mounting and integration.

GENERAL TECHNICAL SPECIFICATIONS

| | |
|---------------------------|-----------------------------------|
| Certificate of Conformity | : Fully compliant with IEC60945 |
| Sealing | : IP68 waterproof |
| Carrier plate | : Stainless steel |
| Ball diameter | : 50,8 mm (2") |
| Ball material | : polyester |
| Dimensions | : 116 x 130 x 50 mm |
| Weight | : 0,6 kg |
| Lifetime trackballs | : >= 2 million ball revolutions |
| Lifetime scroll wheel | : 1 million operations |
| Lifetime switches | : 3 million operations |
| Tracking force | : nom. 50 grams |
| Output | : PS/2 & USB Combo |
| Cable | : 1 shielded, straight 1,6 m long |
| Operating temperatur | : 0°C to +60°C |
| Storage temperature | : -25°C to +80°C |

CONNECTIVITY

Combo PS/2 & USB trackball units are supplied with a 1,6 meter long shielded straight cable ended by a USB type A plug. An adaptor to PS/2 is added. No special device driver is needed, use standard available drivers of your operating system.

* Due to the increasing differences of the PS/2 mouse port specifications of the various PC manufacturers, we do recommend that this unit should be tested on the final PC configuration and operating system prior to installing it in series.



CE

Compliant to EMC for Electromagnetic Compatibility.
Low Voltage not applicable for our trackballs.

ORDER INFO

Front panel mount with studs

| | |
|----------------|--------------------------|
| Blank topplate | LTSX50F8-0001-MC3 |
| Black topplate | LTSX50F8-0BT1-MC3 |



Front panel mount with holes

| | |
|----------------|--------------------------|
| Blank topplate | LTSX50N8-0001-MC3 |
| Black topplate | LTSX50N8-0BT1-MC3 |



Output : PS/2 & USB Combo

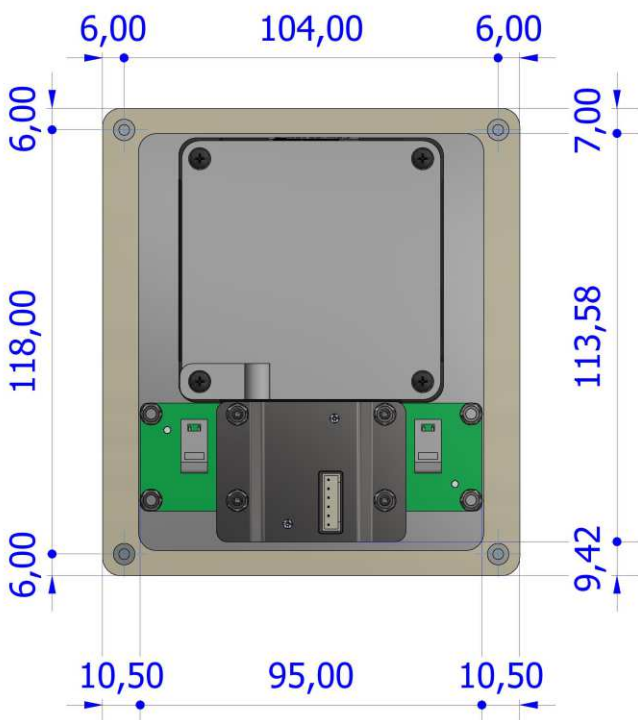
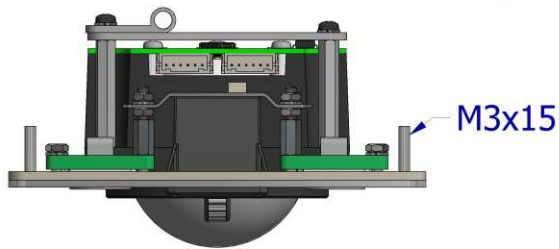
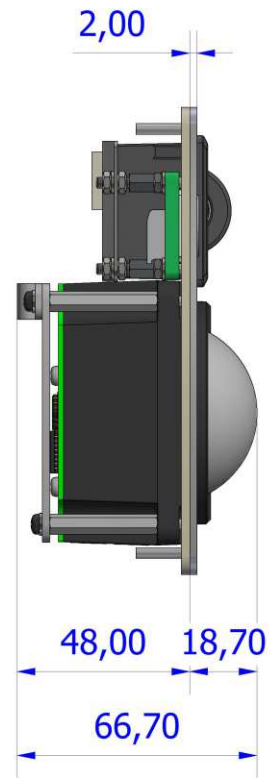
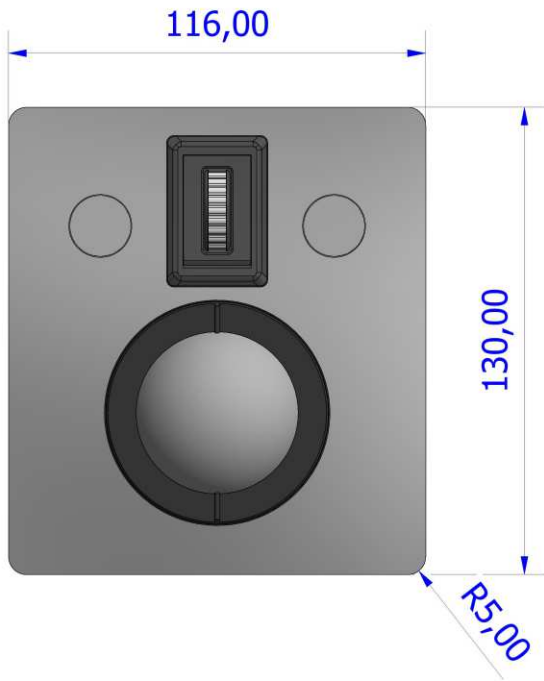

The company reserves the right to alter without prior knowledge the specification or design of any standard product or service.



DIMENSIONAL DRAWING

Front panel mount with holes

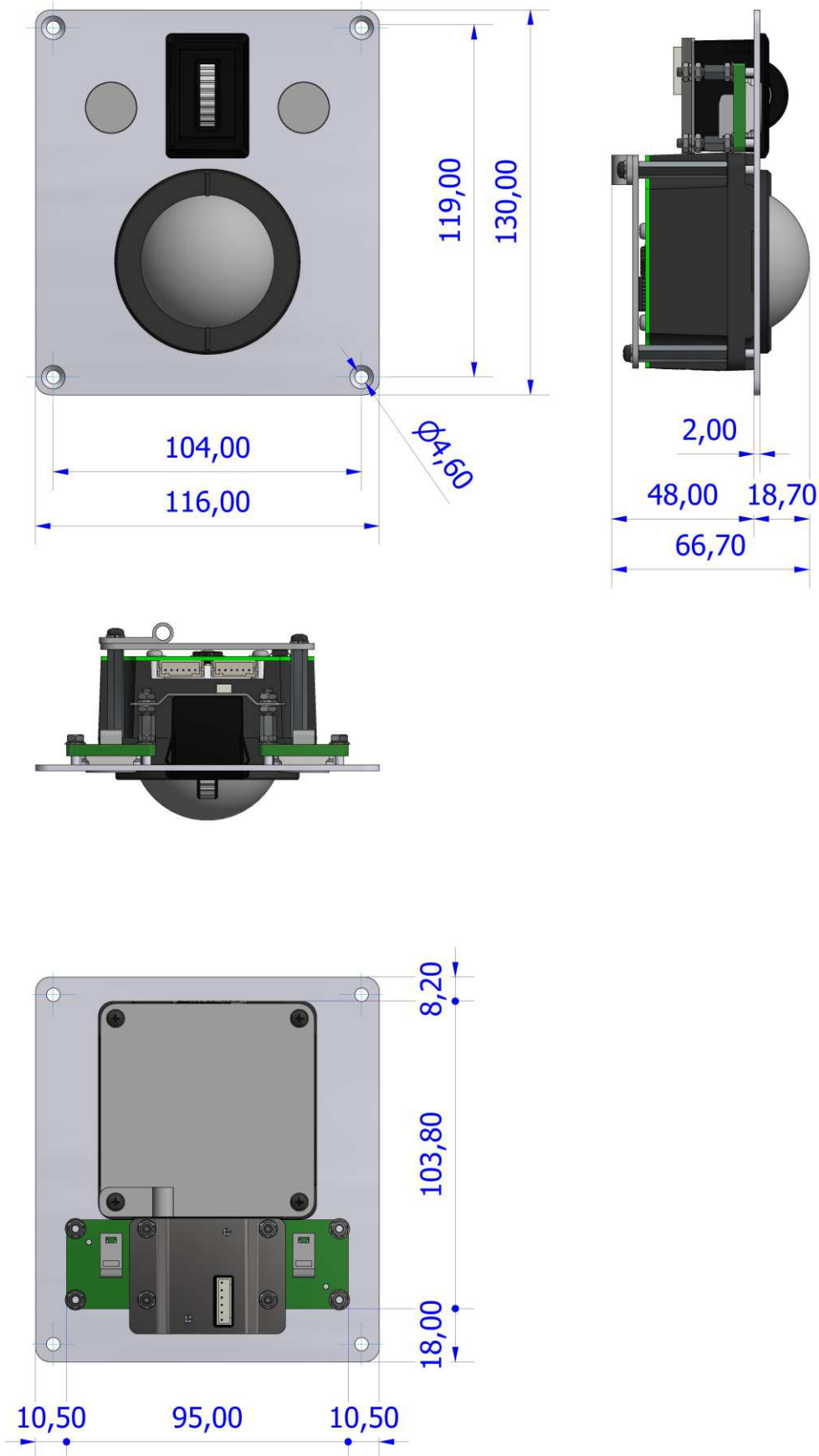

The company reserves the right to alter without prior knowledge the specification or design of any standard product or service.