

# Banga 100 (100A+10A)



## Application

High Power and Lithium Charging

### Advantages

- Snap lock mechanism
- Self-locking button to prevent accidental unlocking
- Up to 6 signal pins
- Audible click when lock engaged
- RoHS and Reach Compliant



## Specifications

Mating Cycle: $\geq 3000$ Times	Voltage Rating: 630V DC	Operating Temperature: $-40^{\circ}\text{C}$ to $105^{\circ}\text{C}$	Shell: High Strength Thermoplastic Resin
Wire Processing: Crimp/ Solder	Current Rating: 100A+10A	IP Rating: IP66 mated; IP67 panel side	Sealing: Silicone Rubber
	Peak Current: Power 180A 30S	Salt Spray: 48h	Conductor: Copper Alloy, Silver/ Gold Plated
	Withstand Voltage: 2500V AC	Flammability Rating: UL94V-0	Wire Gauge: Power 25mm <sup>2</sup> /Max
	Insulation Resistance: $>100\text{M}\Omega$		Signal 20AWG/Max

## Dimensions

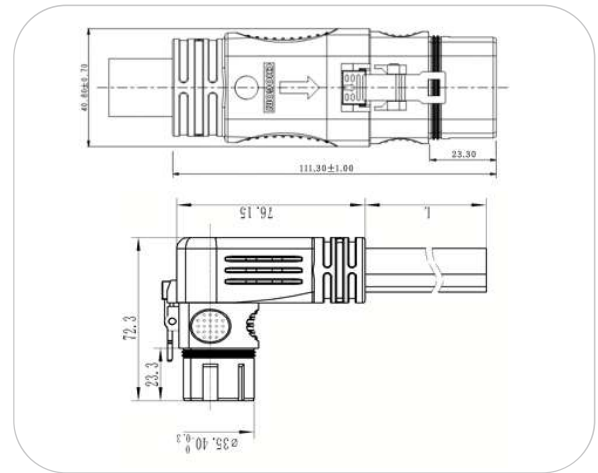
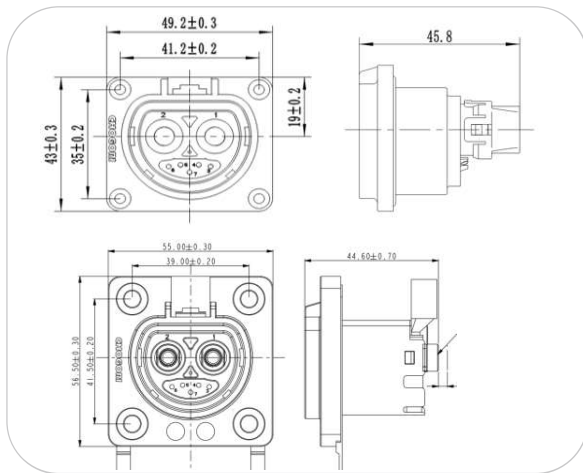

## Temperature Curve

